

DRIVER \_\_\_\_\_  
 TRACK \_\_\_\_\_  
 RACE \_\_\_\_\_ DATE \_\_\_\_\_  
 TEMP \_\_\_\_\_ BEST LAP \_\_\_\_\_ BEST RESULT \_\_\_\_\_

TRACK SIZE  TIGHT  MEDIUM  OPEN  
 SURFACE  DUSTY  BLUE GROOVE  LOW GRIP  MEDIUM GRIP  HIGH GRIP  
 CONDITION  SMOOTH  BUMPY  50/50  CLAY  GROOVE WITH DUST  EGY  
 QUALIFYING POS. \_\_\_\_\_ FINAL POS. \_\_\_\_\_

ENGINE _____	CLUTCH _____	FRONT DIFF OIL _____	OIL QUANTITY (gr) _____	DIFF GEAR _____
PLUG _____	CLUTCH SHOES _____	CENTER DIFF OIL _____	OIL QUANTITY (gr) _____	DIFF PINION _____
PIPE _____	CLUTCH SPRINGS _____	REAR DIFF OIL _____	OIL QUANTITY (gr) _____	SPUR GEAR _____
FUEL _____	RUNTIME _____			CLUTCH BELL _____

**SHOCKS**

	FRONT	REAR
OIL _____		
PISTON _____		
SPRING _____		
LENGTH _____		
VISIBLE SHAFT LENGTH _____		
REBOUND _____		
FRONT SHOCK END <input type="checkbox"/> LONG <input type="checkbox"/> SHORT	SHOCKS <input type="checkbox"/> EMULSION TYPE <input type="checkbox"/> BLADDER	
NOTES		

**FRONT END**

SHOCK TOWER  ALUMINIUM  CARBON

HEX WIDTH  4 mm  5 mm  6 mm

KNUCKLE PLATE  1 LONG  2 SHORT

FRONT ARM POSITION  FRONT  MIDDLE  REAR

ARM INSERT  NO  PLASTIC  CARBON

KNUCKLE POSITION  UP  MIDDLE  DOWN

KPI OPTION  KPI 0 (ROUND MARK)  KPI 1 (LONG MARK)

C BLOCK CASTER  CASTER 1 (1 MARK)  CASTER 2 (2 MARKS)

SERVO SAVER  YES  NO

BUMP STEER ON ACKERMAN  UP  DOWN SHIM \_\_\_\_\_ mm

BUMP STEER ON KNUCKLE  UP  DOWN SHIM \_\_\_\_\_ mm

KICK UP

1 <input type="checkbox"/>	0,5 <input type="checkbox"/>	0 <input type="checkbox"/>	0,5 <input type="checkbox"/>	1 <input type="checkbox"/>
1 <input type="checkbox"/>	0,5 <input type="checkbox"/>	0 <input type="checkbox"/>	0,5 <input type="checkbox"/>	1 <input type="checkbox"/>

A PLATE B PLATE TOWER

+2mm SHIM (NO upper gearbox shim) +2

+1mm SHIM (1mm upper gearbox shim) +1

NO SHIM (2mm upper gearbox shim) 0

**CHASSIS**

	FRONT	REAR
CAMBER _____		
RIDE HEIGHT _____		
DOWNTRAVEL (WITH TYRES) _____		
DOWNTRAVEL (on 36mm blocks) _____		
ANTI ROLL BARS _____		
BRAKE BALANCE _____		
ENGINE MOUNT <input type="checkbox"/> FORWARD (+2mm) <input type="checkbox"/> SHORT <input type="checkbox"/> BACKWARD (-2mm) <input type="checkbox"/> LONG		
THROTTLE <input type="checkbox"/> SHORT <input type="checkbox"/> LONG	WEIGHT _____	

**REAR END**

ARM INSERT  NO  PLASTIC  CARBON

SHOCK TOWER  ALUMINIUM  CARBON

OPTIONAL REAR HUB

REAR HUB  PLASTIC  ALUMINIUM

HEX WIDTH  4 mm  5 mm  6 mm

SPACER IN FRONT OF HUB \_\_\_\_\_ mm

REAR AXLE CVD  UNIVERSAL  91  94

ANTI-SQUAT

1 <input type="checkbox"/>	0,5 <input type="checkbox"/>	0 <input type="checkbox"/>	0,5 <input type="checkbox"/>	1 <input type="checkbox"/>
1 <input type="checkbox"/>	0,5 <input type="checkbox"/>	0 <input type="checkbox"/>	0,5 <input type="checkbox"/>	1 <input type="checkbox"/>

C PLATE D PLATE TOWER

+2mm SHIM +2

+1mm SHIM +1

NO SHIM 0

**TYRES**

	FRONT	REAR
BRAND _____		
TREAD _____		
COMPOUND _____		
WHEELS _____		
INSERTS _____		
GLUED TO WHEEL <input type="checkbox"/> YES <input type="checkbox"/> NO	<input type="checkbox"/> YES <input type="checkbox"/> NO	

**RADIO SETTINGS**

	THROTTLE	STEERING
DUAL RATE _____		
SPEED _____		
EXPO _____		
SERVO MODEL _____		
	THROTTLE	BRAKE
ELECTRIC EPA _____		

**BODY & WING**

BODYSHELL \_\_\_\_\_

WING BRAND \_\_\_\_\_

WING MODEL \_\_\_\_\_

WING POSITION  1  2  3  4  
1 IS FRONT HOLE (WING BACK)

WING FLAPS  BIG  SMALL  BOTH

GURNEY  NO  SMALL  BIG

**NOTES**

\_\_\_\_\_

\_\_\_\_\_

\_\_\_\_\_

\_\_\_\_\_

\_\_\_\_\_

**FRONT END - UPPER ARMS**

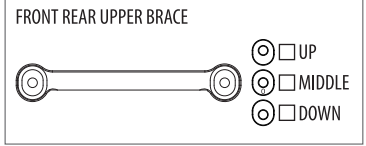
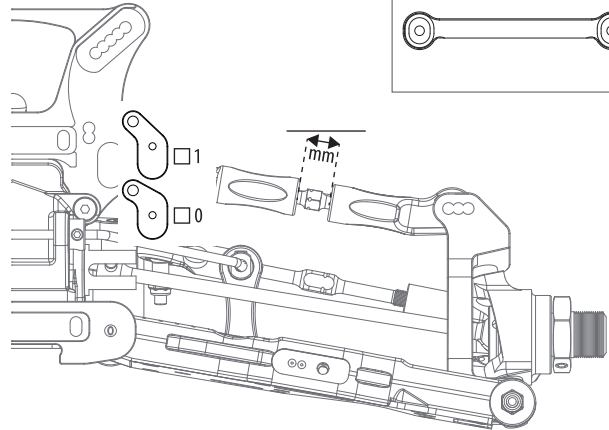
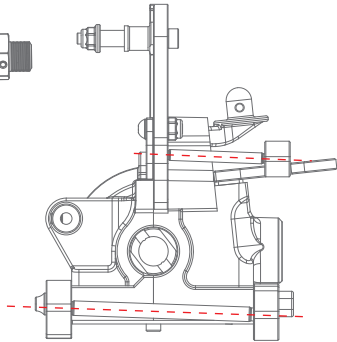
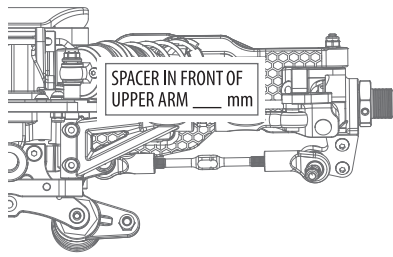

**REAR END - UPPER ARMS**

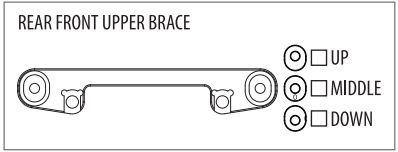
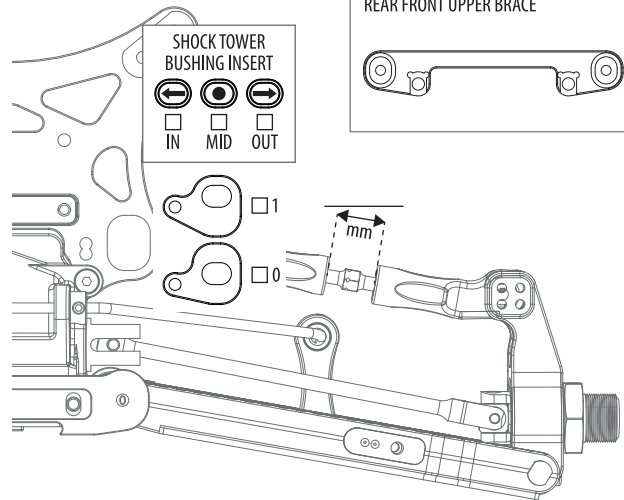
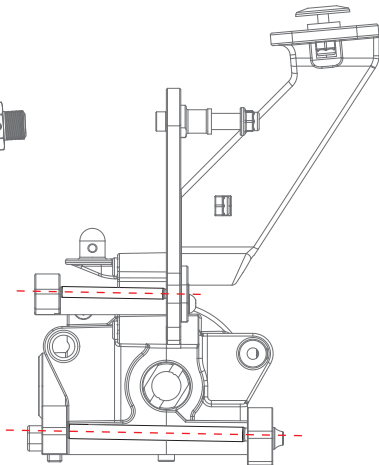
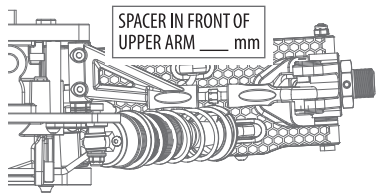

**ADJUSTING UPPER ARMS**

The upper arm angle is to be matched to the lower arm angle. There is a compromise for the upper arm, as a .5 change for the upper arm is so small.

**The way to understand how to adjust the upper arm is as follows**

1. When you have the same inserts, in the same direction in the front and rear blocks (A-B, or C-D), you should use the 0 insert for the upper arm.

*Example:*

When you run 0-0, .5 down - .5 down, or 1 up - 1 up in the A-B, or C-D blocks, those are all examples of running the same inserts and direction in both blocks. This means you should run the 0 (middle) insert for the upper arm.

2. When you have a 1mm difference between the inserts in the front and rear blocks (A-B, or C-D), you need to use the 1 (end) insert for the upper arm, in the same direction as the lower arm is angled, either larger or smaller angle.

*Example:*

When you run 0-1 down, 1 up - 0, or .5 up - .5 down, those are all examples of a 1mm difference and a larger angle.

You would need to run the 1 insert (end) down for the upper arm, making it a larger angle to match.

The opposite is true when you reduce the lower arm angle by a 1mm difference.

3. When you have a .5 difference between the inserts in the front and rear blocks (A-B, or C-D), you can chose to run either the 0 insert, or the 1 insert for the upper arm, matching the direction of the angle change of the lower arm.

*Example:*

When you run 0 - .5 up, .5 down - 0 or 1 down - .5 down, those are all examples of a .5mm difference and a smaller angle.

You would need to run the 0 insert, or 1 insert up for the upper arm. The opposite is true when you increase the lower arm angle by a .5mm difference.

**The way to understand how to adjust the upper arm related to TOE IN is as follows**

1.5° toe in: arrow inwards

3.0° toe in: arrow outwards